

The information disclosed herein is the property of the originator who reserves all patent, design, proprietary, manufacturing, use and sales rights thereto, except for the rights expressly granted to others. This document shall not be reproduced nor shall the information contained within be used by or disclosed to others except as expressly authorized by the originator.

Revision Letter	Change Description
A	-10 Fiberglass Ventral Fin Replaced -10 Sheetmetal Ventral Fin. -Removed Items -11, -12, and -14. -Removed CCP-41 Rivets Qty 36. -Added -10 Fiberglass Ventral Fin Detail. 6.17.19

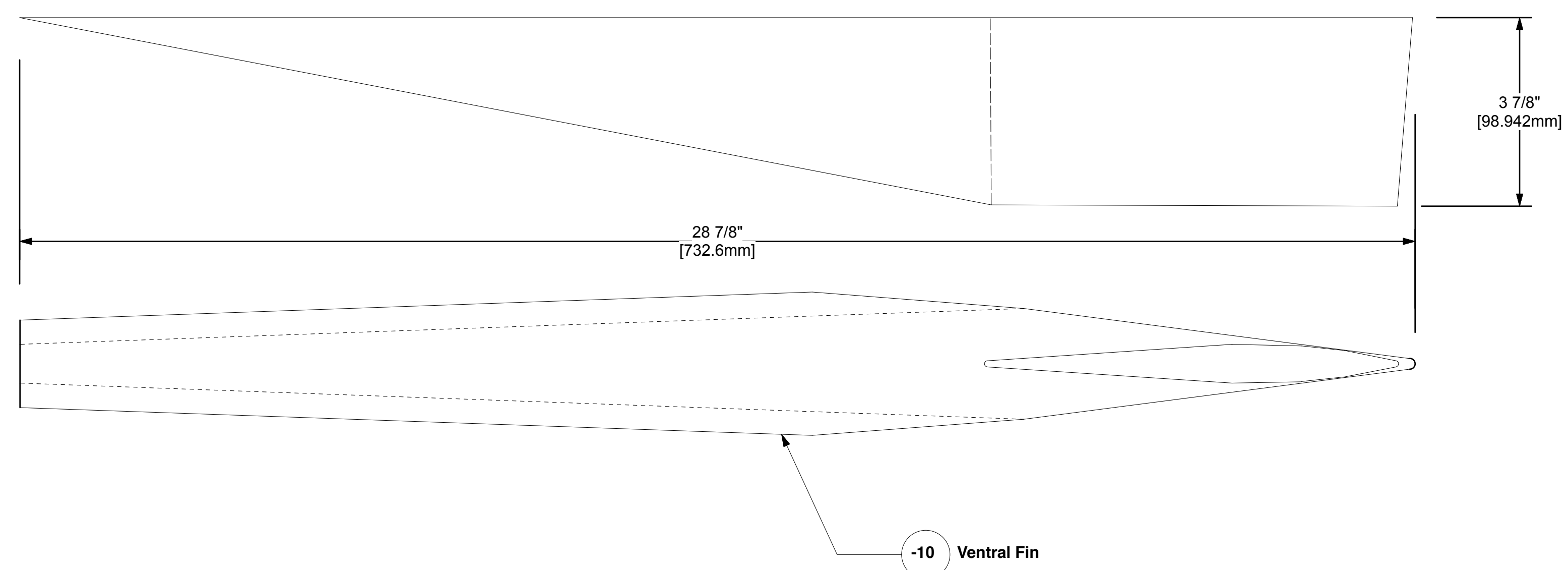
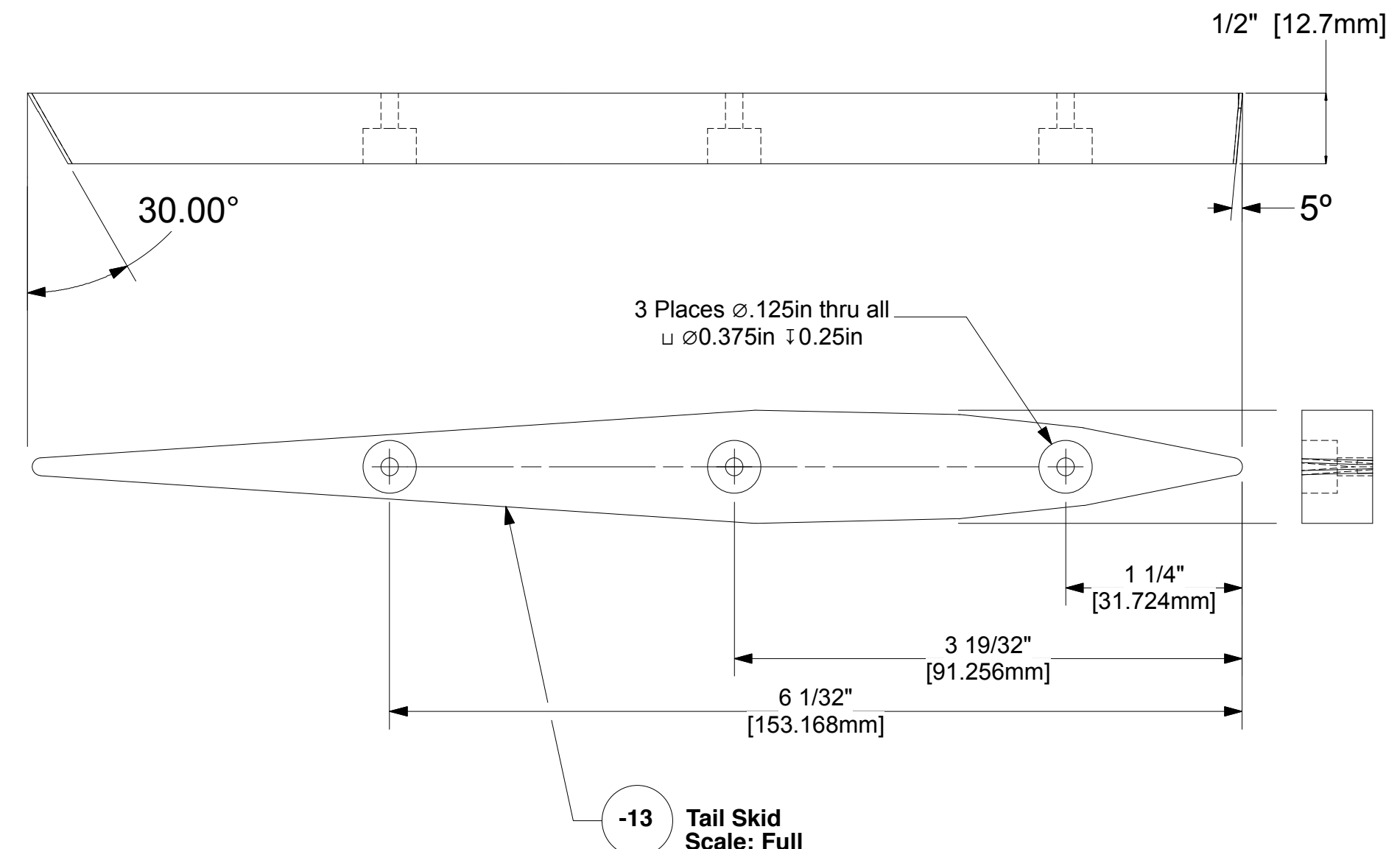
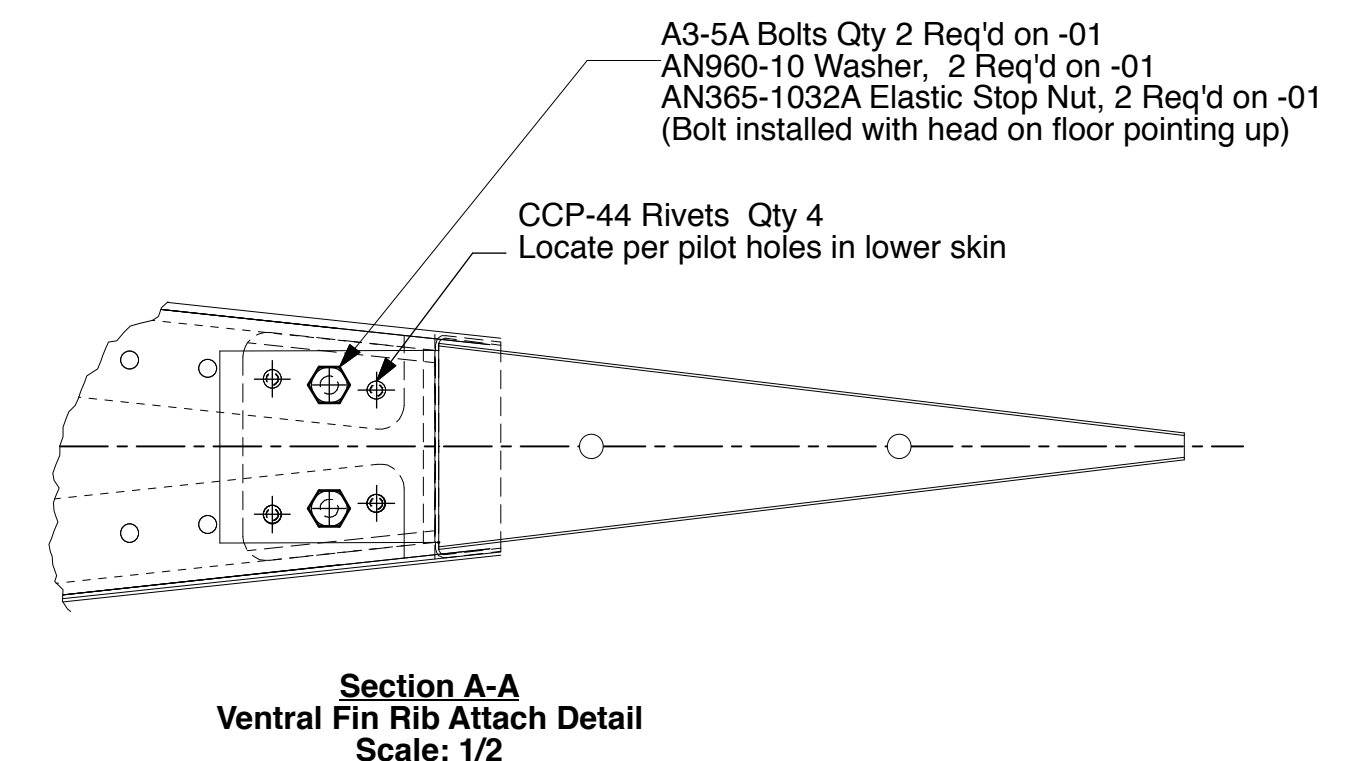
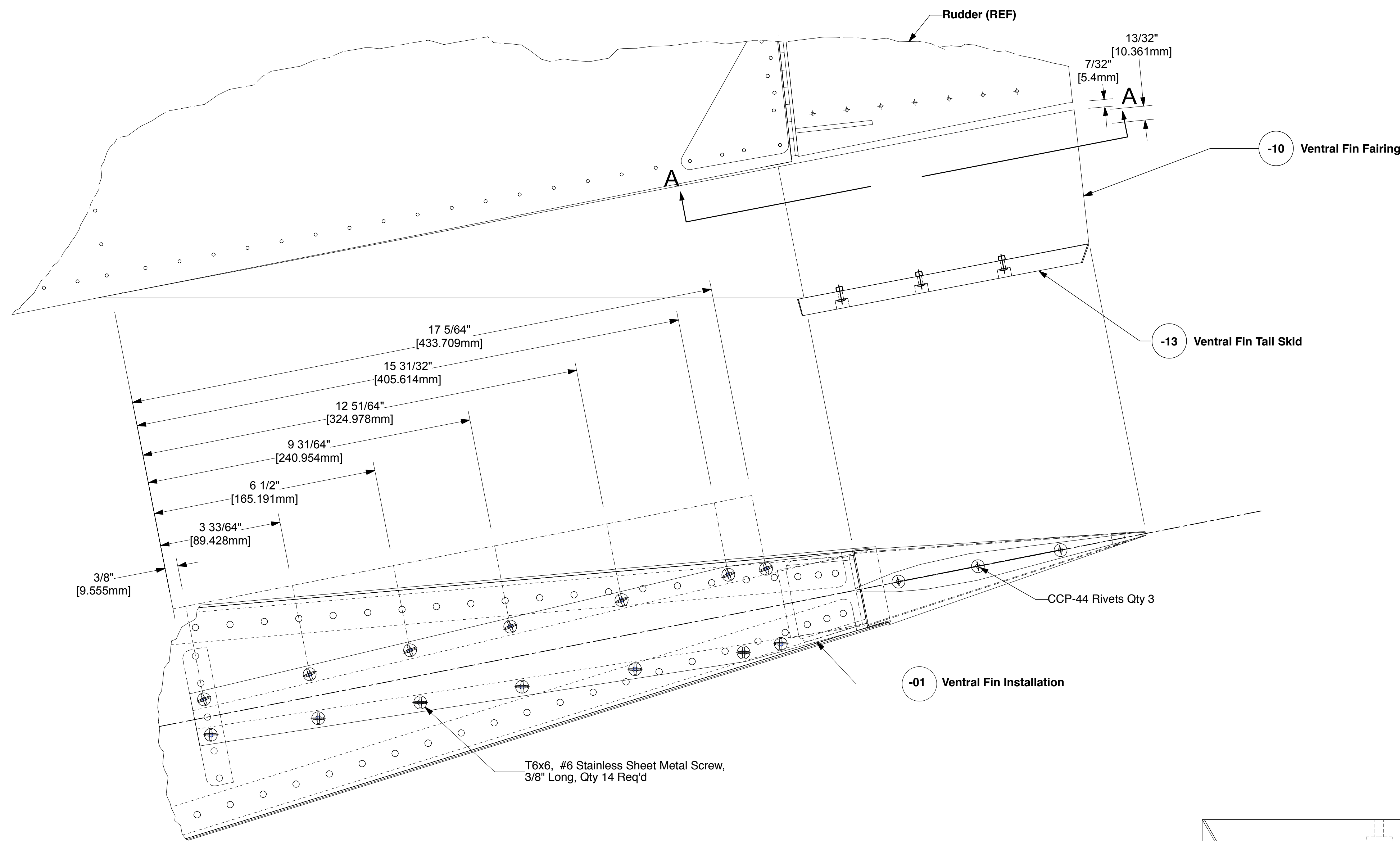

Note: General Construction Order

-01 Ventral Fin Installation
Note: JSX-B04 Assembly must be complete before Ventral Fin is permanently attached.
 1) Assemble Ventral Fin with Tail Skid.
 2) Temporarily attach Ventral Fin to Air Fuselage floor.
 5) Remove Ventral Fin Assembly.
 6) Fill Ventral Fin Assembly with Expanding Foam Insulation, sand flush.
 7) Install Ventral Fin Assembly

-01	1	Ventral Fin Installation	JSX-B04
Dash Number	Quantity Required	Part Title	Next Assembly
Sonex Ventral Fin Installation			
Drawing Scale	Drawing Number	Revision	
1:2 & Noted	JSX-T02	A	